

INGCO

Jig Saw

EN Jig Saw

ES Sierra de calar









JS80028 UJS80028 JS80028S JS80028-1
JS80028-4 JS80028-6 JS80028-8 JS80028-9



SCAN FOR VIDEO



The symbols in instruction manual and the label on the tool

	Double insulated for additional protection.
	Read the instruction manual before using.
	CE conformity.
	Wear safety glasses, hearing protection and dust mask.
	Waste electrical products should not be disposed of with household waste. Please recycle where facilities exist. Check with your Local Authority or retailer for recycling advice.
	Safety alert. Please only use the accessories supported by the manufacture.

GENERAL POWER TOOL SAFETY WARNINGS

WARNING Read all safety warnings and all instructions. Failure to follow the warnings and instructions may result in electric shock, fire and/or serious injury.

Save all warnings and instructions for future reference.

The term "power tool" in the warnings refers to your mains-operated (corded) power tool or battery-operated (cordless) power tool.

1) Work area safety

- a) **Keep work area clean and well lit.** Cluttered and dark areas invite accidents.
- b) **Do not operate power tools in explosive atmospheres, such as in the presence of flammable liquids, gases or dust.** Power tools create sparks which may ignite the dust or fumes.
- c) **Keep children and bystanders away while operating a power tool.** Distractions can cause you to lose control.

2) Electrical safety

- a) **Power tool plugs must match the outlet. Never modify the plug in any way. Do not use any adapter plugs with earthed (grounded) power tools.** Unmodified plugs and matching outlets will reduce risk of electric shock.
- b) **Avoid body contact with earthed or grounded surfaces such as pipes, radiators, ranges and refrigerators.** There is an increased risk of electric shock if your body is earthed or grounded.
- c) **Do not expose power tools to rain or wet conditions.** Water entering a power tool will increase the risk of electric shock.
- d) **Do not abuse the cord. Never use the cord for carrying, pulling or unplugging the power tool. Keep cord away from heat, oil, sharp edges or moving parts.** Damaged or entangled cords increase the risk of electric shock.
- e) **When operating a power tool outdoors, use an extension cord suitable for outdoor use.** Use of a cord suitable for outdoor use reduces the risk of electric shock.
- f) **If operating a power tools in a damp location is unavoidable, use a residual current device (RCD) protected supply.** Use of an RCD reduces the risk of electric shock.

3) Personal safety

- a) **Stay alert, watch what you are doing and use common sense when operating a power tool. Do not use a power tool while you are tired or under the influence of drugs, alcohol or medication.** *A moment of inattention while operating power tools may result in serious personal injury.*
- b) **Use personal protective equipment. Always wear eye protection.** Protective equipment such as dust mask, non-skid safety shoes, hard hat, or hearing protection used for appropriate conditions will reduce personal injuries.
- c) **Prevent unintentional starting. Ensure the switch is in the off-position before connecting to power source and/or battery pack, picking up or carrying the tool.** *Carrying power tools with your finger on the switch or energizing power tools that have the switch on invites accidents.*
- d) **Remove any adjusting key or wrench before turning the power tool on.** *A wrench or a key left attached to a rotating part of the power tool may result in personal injury.*
- e) **Do not overreach. Keep proper footing and balance at all times.** *This enables better control of the power tool in unexpected situations.*
- f) **Dress properly. Do not wear loose clothing or jewellery. Keep your hair, clothing and gloves away from moving parts.** *Loose clothes, jewellery or long hair can be caught in moving parts.*
- g) **If devices are provided for the connection of dust extraction and collection facilities, ensure these are connected and properly used.** *Use of dust collection can reduce dust-related hazards.*

4) Power tool use and care

- a) **Do not force the power tool. Use the correct power tool for your application.** *The correct power tool will do the job better and safer at the rate for which it was designed.*
- b) **Do not use the power tool if the switch does not turn it on and off.** *Any power tool that cannot be controlled with the switch is dangerous and must be repaired.*
- c) **Disconnect the plug from the power source and/or the battery pack from the power tool before making any adjustments, changing accessories, or storing power tools.** *Such preventive safety measures reduce the risk of starting the power tool accidentally.*

- d) **Store idle power tools out of the reach of children and do not allow persons unfamiliar with the power tool or these instructions to operate the power tool.** *Power tools are dangerous in the hands of untrained users.*
- e) **Maintain power tools. Check for misalignment or binding of moving parts, breakage of parts and any other condition that may affect the power tools operation. If damaged, have the power tool repaired before use.** *Many accidents are caused by poorly maintained power tools.*
- f) **Keep cutting tools sharp and clean.** *Properly maintained cutting tools with sharp cutting edges are less likely to bind and are easier to control.*
- g) **Use the power tool, accessories and tool bits etc. in accordance with these instructions, taking into account the working conditions and the work to be performed.** *Use of the power tool for operations different from those intended could result in a hazardous situation.*

5) Service

- a) **Have your power tool serviced by a qualified repair person using only identical.** *This will ensure that the safety of the power tool is maintained.*

Additional Safety Warnings

- 1) Information on the correct use of the dust collection system, if any
- 2) Advice to wear a dust mask

Residual risks

Even when the power tool is used as prescribed it is not possible to eliminate all residual risk factors. The following hazards may arise in connection with the power tool's construction and design:

- a) Health defects resulting from vibration emission if the power tool is being used over longer period of time or not adequately managed and properly maintained.
- b) Injuries and damage to property to due to broken accessories that are suddenly dashed.



Warning! This power tool produces an electromagnetic field during operation. This field may under some circumstances interfere with active or passive medical implants. To reduce the risk of serious or fatal injury, we recommend persons with medical implants to consult their physician and the medical implant manufacturer before operating this power tool.

Dia 1A



Component List

- | | |
|-------------------------------------|-----------------|
| 1. Stroke rate selection thumbwheel | 8. Blade holder |
| 2. Lock switch | 9. Saw blade |
| 3. Trigger switch | |
| 4. Dust collector | |
| 5. Base plate | |
| 6. Pendulum action switch | |
| 7. Parallel guide | |

Accessories:

- 1PCÛ dust collector
- 1PCÛ parallel guide
- 2PCS hex keys
- 1SET carbon brushes

Technical specifications

Model No.	JS80028 JS80028-1 JS8002-4 JS80028-9	UJS80028	
Voltage	220-240V-50/60Hz	110-120V-50/60Hz	
Rated power	800W	800W	
No-load speed	800-3000/min	800-3000/min	
Cutting capacity:Wood	100mm	4"	
	Alu 12mm	15/32"	
	Steel 10mm	3/8"	
Angular cutting range	0±45°	0±45°	
Model No.	JS80028-6 (ISRAEL Plug)	JS80028-8 (BS Plug)	JS80028S (SAA Plug)
Voltage	220-240V-50/60Hz		
Rated power	800W		
No-load speed	800-3000/min		
Cutting capacity:Wood	100mm		
	Alu 12mm		
	Steel 10mm		
Angular cutting range	0±45°		

OPERATION**Fitting The Saw Blade(see Dia 2)**

When changing blades, set pendulum action switch to "0"

To open the blade holder, rotate the ring anti-clockwise (jig saw upside down) and hold in position. Then fully insert the blade into the blade holder slot with blade teeth facing forward and release the ring, which will self rotate and clamp over the top of the blade. Push the blade into the blade holder again to ensure it is locked in position. Ensure the edge of the blade is located in the groove of the support roller. To remove blade, hold the blade and rotate the ring anti-clockwise then lift out the blade.

Warning:

Blade teeth are very sharp.
Blade self-eject out swiftly. Do not point at people

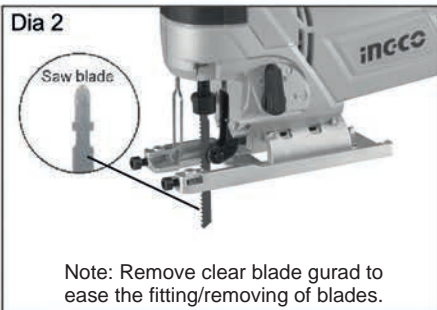
**Using the parallel guide(see Dia 3)**

The parallel guide allows you to make an accurate parallel cuts using the metric scale. Release the quick set mechanism on the parallel guide. Put it into the required position and lock quick set mechanism again. Slide the parallel guide in from the appropriate side(left or right) accordingly. Make sure that the guide surface of the parallel guide points downwards.

**Assemble vacuum chip extraction adaptor:**

Note: only use the equipment with a compatible vacuum chip extractor, insert the extractor into the back of the jig saw, rotate the vacuum hose to the extraction nozzle and test whether it is securely held in place. See Dia 4.

**Operating the Trigger Switch (see Dia 5)**

To operate the Pendulum jig saw, depress the trigger switch. If you wish to use the Pendulum Jig saw continuously, the trigger lock button can be pushed in after the trigger switch has been depressed. To release the lock button push in the trigger switch again.



Pendulum Action Switch Adjustment (see Dia 6)

The saw blade pendulum action, adjustable in four steps, makes possible the optimum adaptation of saw advancing (cutting speed), cutting performance and cut appearance of the material. For each downward movement, the saw blade is lifted off the material which facilitates sawdust ejection, reduces heat generated by friction and increases the service life of the saw blade. At the same time the reduction of the necessary advancing force makes fatigue-free working possible. The pendulum action switch makes possible the adjustment of the pendulum action in four steps. The switching can take place with the machine running:

Pendulum Setting:

Step 0: No pendulum action

Material: rubber, ceramic, aluminium, steel

Step 1: Small pendulum action

Material: plastic, wood, aluminium

Step 2: Medium pendulum action

Material: wood

Step 3: Large pendulum action

Material: wood

Generally, the finer and cleaner the cut edge should be the smaller the pendulum step selected should be or switch off the pendulum action. For the working of thin material such as sheet metal, switch off the pendulum action (Step 0). In hard material such as steel, work with small pendulum action. In materials such as soft wood and cutting in the direction of the grain, the large pendulum action can be used.

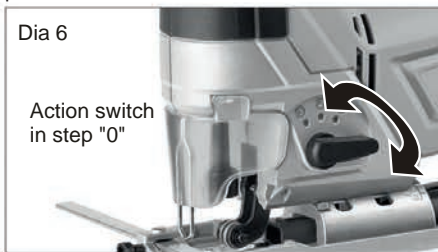

Stroke Rate Selection (see Dia 7)

With the thumbwheel, the required stroke rate can be selected (also while running).

MIN-2 = Low stroke rate

3-4 = Medium stroke rate

5-MAX = High stroke rate

The stroke rate required depends upon the material and the working conditions: fast enough to make reasonable progress, but slow enough to keep a clean cut and to avoid straining the machine. Generally, finer saw blades use a higher speed, coarser blades use a slower speed. After working for longer periods at low stroke rate allow the machine to cool by running it at maximum stroke rate and no load for approx 3 minutes.

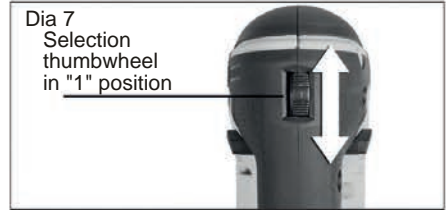

Using The Pendulum Jig saw

Before using the saw and connecting the mains cable make sure the trigger switch is in the off position. Press the trigger switch and wait until blade has reached maximum speed. Place the front of the baseplate on the workpiece and line up the cutting line with the line you wish to cut. Push slowly forward. Keep the baseplate flat against the workpiece.

Cutting Metal

An appropriate cutting agent (such as light oil, small amounts of soapy water, etc) should always be used. If there is no available liquid cutting agent, grease can be applied to the back surface of the material to be cut.

Cutting Grooves/Window Holes

(see Dia 8)

For wood: Align the blade direction with the grain of the wood. Then position the rounded part at the front of the base plate on surface to be cut, slowly lower the saw into material at chosen point of entry. Lower the saw in a pivoting action until blade has cut through to other side, do not move saw along intended cut line until the blade has cut through and base plate is laying flat on material.

For other materials: In materials other than wood when cutting window holes, first use a drill or similar tool to drill a hole from which initial cutting will begin.

Dia 8



Angular Cutting

The angle adjustment screw has combined with the lever. To adjust the angle of inclination, loosen the angle adjustment screw by turning the lever anticlockwise. See dia 9.



Dia 9

You will then be able to rotate the base plate to the required angle 0~ 45° to the left or right. Angle of inclination numbers are stamped onto the fan shaped bracket on back of the base plate to help you set the correct angle. Check the support roller before tightening. Firmly tighten the angle adjustment screw by turning the lever clockwise for operation. See dia10

Dia 10

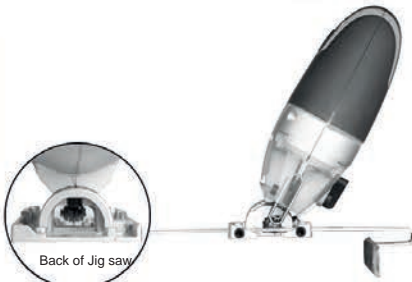

Back of Jig saw



Disengage and set the lever to touch the saw body, or the lever will hit the workpiece.

Note: To achieve a sufficient looseness or a good tight fit of the base plate, you may need to turn the lever repeatedly when loosening/ tightening the angle adjustment screw. The lever has an engagement/disengagement system. Pull the lever backwards to disengage whilst the lever is turned to the leftmost or rightmost position, and then reverse the lever, further tighten/loosen the screw as necessary, see dia 11.



Dia 11

TROUBLESHOOTING

1. If your jig saw will not operate, check the fuse and the power at the mains plug.
2. If the jig saw is not cutting properly check the blade and support roller, replace blade if worn. Also check the cutting angle, the blade must be at exactly 90° to the base plate for normal use.
3. If a fault can not be found return the saw to an authorised dealer for repair.
4. There are no user serviceable parts in the jig saw.

Maintenance of the Jig saw

1. Clean the jig saw regularly(remove chips and bits of wood etc.). For the best results do this straight after the work has been completed.
2. Do not allow liquids to get inside the jig saw. Use a soft cloth for cleaning the housing. Do not use petrol, solvents or cleaners that may attack the plastic.
3. Air vents must always be clear and clean.

Advice on working methods, tips

1. Here is some advice on the pendulum action control: the saw blade is only pressed against the material on the return stroke/working stroke. It is moved away from the material on the forward stroke. The result is better removal of chips, less friction and therefore a higher output.
2. To avoid the jig saw springing up and down when sawing sheets, support the sheet on timbers. When sawing metal, apply a coolant oil along the cutting line.
3. Adjust the speed and the pendulum action settings to suit the material to be sawn. We always recommend that you carry out a test cut first.
4. To use the jig saw put the front end of the base plate on the material and turn the machine on. Press the machine from above on to the material and guide the jig saw along the cutting line.
5. Do not use too much pressure to achieve the best progress when sawing, use light pressure on the saw blade.
6. When sawing along a marked line use the marking on the splitting guard as a guide.
7. For exact cutting, clamp a timber batten on to the material as an aid or use the parallel guide.
8. For mitres/bevels, set the base plate in the required position.
9. Set the base plate to its rearmost position for cutting close to an edge.

INGCO

EXPLODED VIEW

JS80028,UJS80028,JS80028-1,JS80028-4,JS80028-6,JS80028-8,JS80028-9,JS80028S

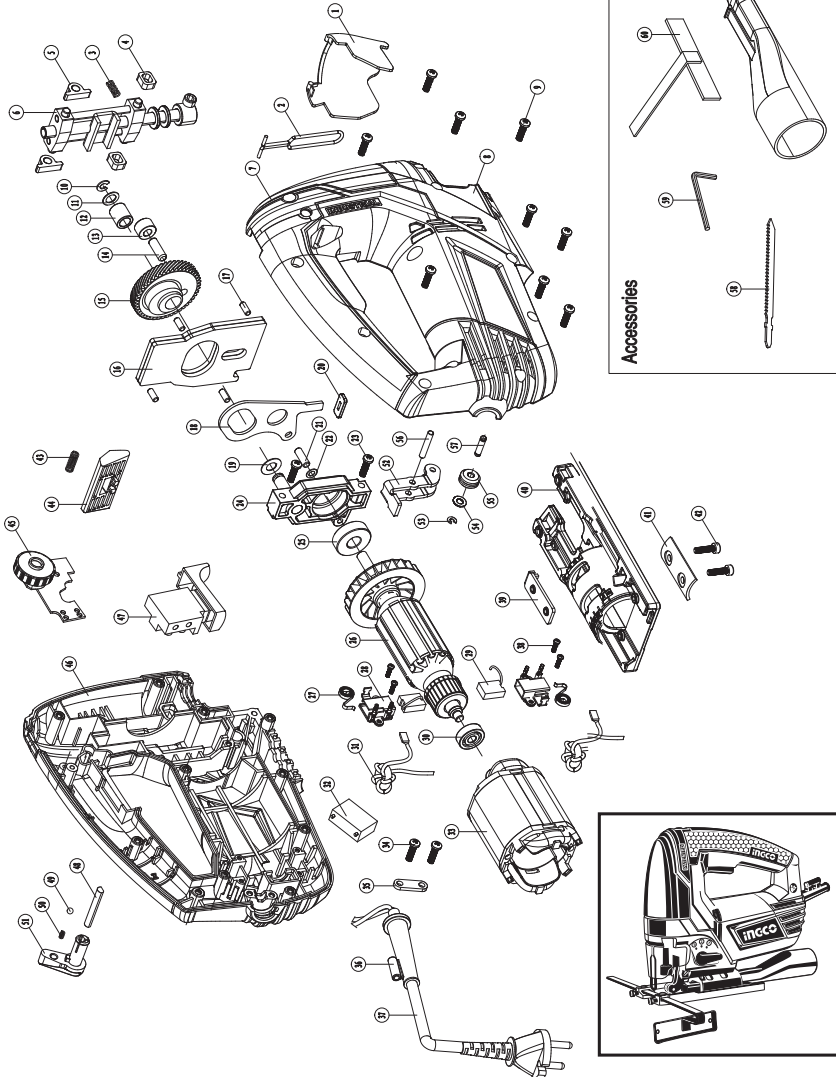



SPARE PART LIST

JS80028,UJS80028,JS80028-1,JS80028-4,JS80028-6,JS80028-8,JS80028-9,JS80028S

No.	Part Description	Qty	No.	Part Description	Qty
1	Transparent cover	1	32	Capaci tor (option)	1
2	Steel-Spring	1	33	Stator	1
3	Allocation-slide block	2	34	Screw ST4 x 13	2
4	spring	1	35	Cable Platen	1
5	Bearing Pedestal	2	36	Cable protecting sleeve	1
6	Sliding rod assy'	1	37	Cable and Plug	1
7	Right housing	1	38	Screw ST2. 9 x 12	4
8	Cover	1	39	Locating board	1
9	Screw 4 x 16	12	40	Base Plate	1
10	Circlip	1	41	Press board	1
11	Washer 8.2 x 16 x 0.5	1	42	Hexagoo Socket Head Cap Screw M4 x 20	2
12	Needle bearing (KK8*12*17)	1	43	Switch-Spring	1
13	Needle bearing (6*12*8)	1	44	Shift Knob	1
14	Pin 6 x 20	1	45	Actiyator	1
15	Gear	1	46	Left housing	1
16	Balance Block	2	47	Switch	1
17	Pin	4	48	Convex pin	1
18	Lift block	1	49	Steel-ball	1
19	Washer8.2 x 24 x 0.5	2	50	Knob-Spring	1
20	dustproof board	1	51	Knob	1
21	Pin 5 x 17	1	52	Lift board	1
22	Washer 5.2 x 10x0.5	1	53	circlip	1
23	Screw 4. 2 x 20	2	54	Washer 4. 2 x8x0.5	1
24	Middle cover	1	55	Pulley	1
25	Bearing 6000	1	56	Lift board-Pin	1
26	Rotor	1	57	Pin	1
27	Coil spring	2	58	Saw Blade (option)	1
28	Brush holder	2	59	Spanner	1
29	Brush	2	60	Paralled guide	1
30	Bearing 607	1	61	Dust adaptor	1
31	Inductor (option)	2			

Fig. 1 A



Lista de Componentes

- | | |
|---------------------------|---|
| 1. Selector | 6. Interruptor del péndulo |
| 2. Bloqueo de interruptor | 7. Guía paralela |
| 3. Gatillo | 8. Herramienta para liberar la cuchilla |
| 4. Adaptador de extractor | 9. Hoja de sierra |
| 5. Placa base | |

Accesorios

- 1 Tubo para el polvo
- 1 Guía paralela
- 2 Llave hexagonal

Especificaciones Técnicas

Model No.	JS80028 JS80028-1 JS80028-4 JS80028-9	UJS80028
Voltage	220-240V-50/60Hz	110-120V-50/60Hz
Watlaje	800W	800W
Velocidad sin carga	800-3000/min	800-3000/min
Profundidad de corte:		
Madera	100mm	4"
Acero	10mm	3/8"
Rango de corte angular	0±45°	0±45°
Model No.	JS80028-6 JS80028-8 JS80028S	
Voltage	220-240V-50/60Hz	
Watlaje	800W	
Velocidad sin carga	800-3000/min	
Profundidad de corte:		
Madera	100mm	
Acero	10mm	
Rango de corte angular	0±45°	

FUNCIONAMIENTO

Montaje de la hoja (ver Fig. 2)



Al cambiar las cuchillas, poner el interruptor del péndulo en "0".

Para abrir el soporte de la cuchilla, gire el anillo hacia la izquierda (sierra de calar al revés) y mantenerlo en posición. Luego inserte totalmente la cuchilla en la ranura de soporte de la cuchilla con los dientes de la hoja hacia adelante y suelte el anillo, el cual rotará por sí mismo y se sujetará sobre la parte superior de la hoja. Empuje la cuchilla en el soporte de la cuchilla de nuevo para asegurarse de que está bloqueada en su posición. Asegurar el borde de la cuchilla se encuentra en la ranura del rodillo de apoyo. Para quitar la hoja, mantenga la hoja y gire el anillo en sentido anti-horario y levante la cuchilla.

Advertencia:

Los dientes de la hoja están muy afilados. La propia hoja se expulsa con rapidez. No la apunte hacia la gente.

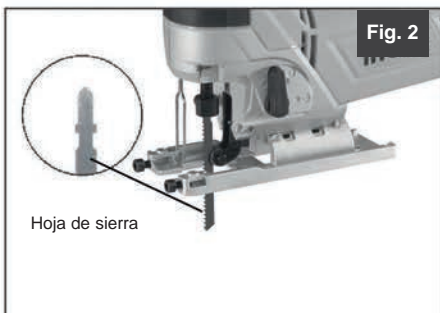

Uso de la guía paralela (ver Fig. 3)

La guía paralela le permite hacer cortes paralelos exactos utilizando el sistema métrico decimal. Libere el mecanismo de configuración rápida de la guía paralela. Póngalo en la posición deseada y bloquéelo otra vez. Deslice la guía paralela en el lado correspondiente (izquierda o derecha). Asegúrese de que la superficie de guía coincide con los puntos de guía en la parte baja.



Ensamble del adaptador de extracción:

Nota: Sólo utilice el equipo con un extractor de viruta compatible, inserte el extractor en la parte posterior de la sierra de calar, gire la manguera de la aspiradora a la boquilla de extracción y compruebe si está bien asegurada en su lugar. Ver Fig. 4.



Uso del interruptor del gatillo (ver Fig. 5)

Para hacer funcionar la caladora oprima el gatillo. Si desea utilizarla de forma continua, presiones el botón de bloqueo de disparo después de que el gatillo ha sido presionado. Para soltar el pulsador de bloqueo presione el gatillo de nuevo.



Interruptor de ajuste de movimiento pendular (ver Fig. 6)

La acción del péndulo en la hoja de corte, ajustable en cuatro pasos, hace posible la adaptación óptima del avance de la sierra (la velocidad de corte), el rendimiento de corte y el aspecto del corte. Para cada movimiento descendente, la hoja de sierra se levanta del material lo que facilita la eyección del aserrín, reduce el calor generado por la fricción y aumenta la vida útil de la hoja de sierra. Al mismo tiempo reduce la fuerza necesaria de avance trabajando con el menor esfuerzo posible. El interruptor de acción del péndulo hace posible el ajuste de la acción de péndulo en cuatro pasos. La conmutación se puede realizar con la máquina en marcha:

Configuración del péndulo:

Paso 0: Sin movimiento pendular

Material: caucho, cerámica, aluminio, acero

Paso 1: movimiento pendular pequeño

Material: plástico, madera, aluminio

Paso 2: movimiento pendular Medio

Material: Madera

Paso 3: movimiento pendular grande

Material: Madera

En general, el borde más fino y más limpio en el corte debe ser seleccionando el paso más pequeño del péndulo o desconectar la acción de péndulo. Para el trabajo de un material delgado como láminas de metal, apague el movimiento pendular (Paso 0). En material duro como el acero, trabaje con movimiento pendular pequeño. En materiales tales como madera blanda y de corte en la dirección de la veta, puede utilizar la acción del péndulo grande.



Selección del tipo de golpe (ver fig. 7)

Con la rueda de ajuste, puede seleccionar el tipo de golpe (también durante la ejecución).

MIN-2 = Tasa baja

3-4 = Tasa media

5-MAX = Tasa alta

La tasa del golpe requerida depende del material y las condiciones de trabajo: lo suficientemente rápida como para tener un progreso razonable, pero lo suficientemente lenta como para mantener un corte limpio y evitar forzar la máquina. Por lo general, las hojas de sierra más finas deben utilizar una velocidad alta, mientras que las gruesas, una más lenta. Después de trabajar durante largos períodos en la tasa baja, permita que la máquina se enfríe ejecutándola a una velocidad máxima y sin carga durante aproximadamente 3 minutos.



Uso de la sierra caladora pendular

Antes de usar la sierra y conectar el cable de red, asegurarse de que el gatillo está en la posición de apagado. Presione el gatillo y espere hasta que la cuchilla ha alcanzado la velocidad máxima.

Coloque la parte delantera de la placa base sobre la pieza y alinee la línea de corte con la línea que desea cortar. Empuje lentamente hacia adelante. Mantenga la placa de base plana contra la pieza de trabajo.

Cortando el metal

Siempre debe utilizar un agente de corte apropiado (como el aceite de corte, pequeñas cantidades de agua y jabón, etc.). Si no hay un fluido de corte disponible, puede aplicar grasa en la superficie posterior del material a cortar.

Cortar ranuras o agujeros de ventana (ver fig. 8)

Para la madera: Alinear la dirección de la cuchilla con la veta de la madera. A continuación, coloque la parte redondeada en la parte delantera de la placa de base sobre la superficie a cortar, baje lentamente la sierra en el material en el punto deseado de entrada. Baje la sierra en una acción de giro hasta que la cuchilla haya atravesado el otro lado, no mueva la línea de sierra a lo largo de la línea de corte hasta que la cuchilla haya atravesado y la placa base esté en posición horizontal en el material.

Para otros materiales: En los materiales distintos de la madera cuando corte los agujeros de ventana, en primer lugar utilizar un taladro o una herramienta similar para hacer un agujero de donde comenzará el corte.



Corte angular

El tornillo de ajuste del ángulo se combina con la palanca. Para ajustar el ángulo de inclinación, aflojar el tornillo de ajuste del ángulo en sentido anti-horario. Ver fig. 8.



A continuación, girar la placa base hasta el ángulo deseado 0 - 45 ° a la izquierda o a la derecha. Los números de los ángulos de inclinación están grabados en el soporte en forma de abanico en la parte posterior de la placa base para ayudar a establecer el ángulo correcto. Compruebe el rodillo de apoyo antes de apretar. Apriete bien el tornillo de ajuste del ángulo de giro de la palanca hacia la derecha para su operación. Ver Fig. 10

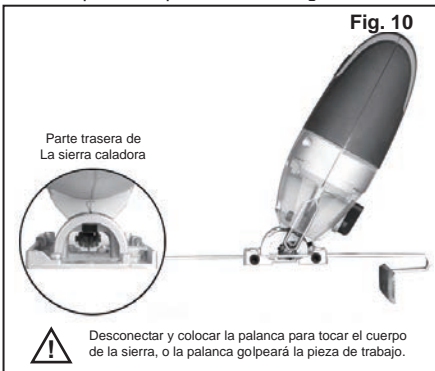

Nota: Para lograr una holgura suficiente o una buena apretada de la placa base, puede que tenga que girar la palanca varias veces al aflojar / apretar el tornillo de ajuste del ángulo. La palanca tiene un sistema unión / desconexión. Tire de la palanca hacia atrás para liberar, al mismo tiempo la palanca se coloca en la posición más a la izquierda o la derecha, y luego revertir la palanca, luego apretar / aflojar el tornillo cuanto sea necesario, ver fig. 11.

SOLUCIÓN DE PROBLEMAS

1. Si su sierra caladora no funciona, revise el fusible y la energía en el enchufe de la red.
2. Si la sierra caladora no está cortando correctamente, compruebe el rodillo de la hoja y el apoyo, cambiar la cuchilla si está desgastada.
También compruebe el ángulo de corte, la hoja debe estar exactamente a 90 de la placa base para el uso normal.
3. Si no puede encontrar la falla, lleve la sierra a un distribuidor autorizado para su reparación.
4. No hay piezas reparables por el usuario en la sierra caladora.

Mantenimiento de la sierra caladora con láser

1. Limpie la sierra caladora de forma regular (retirar virutas y trozos de madera, etc.) Para obtener los mejores resultados hacer esto inmediatamente después de completar el trabajo.
2. No permita que entren líquidos en el interior de la sierra de calar. Utilice un paño suave para limpiar la carcasa. No utilice gasolina, disolventes o productos de limpieza que pueden atacar el plástico.
3. Los orificios de ventilación debe estar siempre despejados y limpios.

Asesoramiento sobre métodos de trabajo, consejos

1. He aquí algunos consejos sobre el control de la acción del péndulo: la hoja de sierra sólo se presiona contra el material en la carrera del golpe / carrera de trabajo. Se mueve lejos del material en la carrera de avance. El resultado es una mejor eliminación de las virutas, menos fricción y por lo tanto una mayor producción.
2. Para evitar que la sierra caladora salte arriba y abajo, apoyar la hoja en la madera. Cuando se trabaja con metal, aplicar un aceite refrigerante a lo largo de la línea de corte.
3. Ajustar la velocidad y la configuración de acción del péndulo en función del material a cortar. Nosotros siempre recomendamos que lleve a cabo un corte de prueba en primer lugar.
4. Para utilizar la sierra caladora, poner el extremo frontal de la placa de base en el material y encender la máquina. Presione la máquina desde arriba sobre el material y guiar la caladora a lo largo de la línea de corte.
5. No utilice demasiada presión para lograr el mejor progreso en el aserrado, haga uso de una ligera presión sobre la hoja de sierra.
6. Al cortar a lo largo de una línea marcada utilizar la marca en la división del protector como una guía.
7. Para el corte exacto, sujetar un listón de madera sobre el material como una ayuda o el uso de la guía paralela.
8. Para mitras o biseles, establezca la placa base en la posición deseada.
9. Ajuste la placa base en su posición más retrasada para cortar cerca de un borde.

INGCO



INGCO TOOLS CO., LIMITED

www.ingco.com

MADE IN CHINA

0519.V08

JS80028 UJS80028 JS80028S JS80028-1
JS80028-4 JS80028-6 JS80028-8 JS80028-9